



THE GENERAL RADIO

Experimenter



NEW GR900



AND GR874



COMPONENTS

ALSO IN THIS ISSUE

**PRECISION DECADE TRANSFORMER
RESISTIVE VOLTAGE DIVIDERS**

VOLUME 41 • NUMBER 4 / APRIL 1967



IET LABS, INC in the **GenRad** tradition
534 Main Street, Westbury, NY 11590

TEL: (516) 334-5959 • (800) 899-8438 • FAX: (516) 334-5988

www.ietlabs.com

the Experimenter

© 1967— General Radio Company, West Concord, Mass., USA

Published monthly by the General Radio Company

THIS ISSUE

	Page
New GR900 Components.....	3
New GR874 Components.....	5
The Type 1493 Precision Decade Transformer.....	8
New Voltage Dividers Offer Resolution to 10 PPM.....	12
Pulses from the Tone-Burst Generator.....	15
New Publications from General Radio.....	16

GENERAL RADIO COMPANY

West Concord, Massachusetts 01781

* **NEW ENGLAND**
 22 Baker Avenue
 West Concord, Massachusetts 01781

* **METROPOLITAN NEW YORK**
 845 Broad Avenue
 Ridgefield, New Jersey 07657

PHILADELPHIA
 Fort Washington Industrial Park
 Fort Washington, Pennsylvania 19034

* **WASHINGTON and BALTIMORE**
 Post Office Box 1160
 11420 Rockville Pike
 Rockville, Maryland 20850

ORLANDO
 113 East Colonial Drive
 Orlando, Florida 32801

SYRACUSE
 Pickard Building, East Molloy Rd.
 Syracuse, New York 13211

CLEVELAND
 5579 Pearl Road
 Cleveland, Ohio 44129

* Repair services are available at these offices

* **CHICAGO**
 9440 W. Foster Avenue
 Chicago, Illinois 60656

* **DALLAS**
 2600 Stemmons Freeway, Suite 210
 Dallas, Texas 75207

* **LOS ANGELES**
 1000 North Seward Street
 Los Angeles, California 90038

SAN FRANCISCO
 Post Office Box 1389
 626 San Antonio Road
 Mountain View, California 94040

MONTREAL
 1255 Laird Boulevard
 Town of Mt. Royal, Quebec, Canada

* **TORONTO**
 99 Floral Parkway
 Toronto 15, Ontario, Canada

GENERAL RADIO COMPANY (OVERSEAS), 8008 Zurich, Switzerland

GENERAL RADIO COMPANY (U.K.) LIMITED, Bourne End, Buckinghamshire, England

REPRESENTATIVES IN PRINCIPAL OVERSEAS COUNTRIES



COAXIAL MICROWAVE NEWS

NEW GR900 COMPONENTS

The GR900 and GR874 lines of coaxial devices continue to expand. The GR900 14-mm precision connector is already backed up by the most extensive line of precision components available, and we now add a precision ell, 13-inch sections of inner-conductor rod for use in fabricating precision air lines, and adaptors to 7-mm precision connectors.

To the long-popular GR874 line we add a bias insertion unit, rod and tube for fabricating air lines, a keyed panel connector, and several new adaptors.

PRECISION ELL



Figure 1.

In precision coaxial measuring systems, the simple matter of going around corners is not so simple, and very careful design is necessary to achieve a right-angle turn that will not introduce reflections. With the introduction of a GR900 precision ell, it is now possible to make a 90-degree turn with a residual *v*swr of less than 1.01 at 1.5 GHz and less than 1.02 at 4 GHz.

The change in direction takes place in a transmission line whose axis describes a 90° circular arc. The uniformly varying change in direction along the arc results in an essentially uniform characteristic impedance.

In the curved region of the ell, the conductors have square cross sections. Where these sections join the standard 14-mm line of round cross sections, coplanar compensation is employed. The ell is, of course, equipped with GR900 precision connectors.

The electrical length of the ell is nominally 10 cm, but, because of the finite curvature, the electrical length increases with increasing frequency.

Uses

The ell is especially useful in systems involving complex interconnections where it is necessary to minimize reflections and to maintain phase linearity as, for instance, in precision phase-and attenuation-measuring systems.

For measurements of dielectric properties with the 900-LB Slotted Line,¹ it is not always convenient to connect the sample holder directly to the slotted line. If, for instance, the dielectric to be measured is a liquid, the sample holder usually must be vertical. Vertical orientation is also often necessary for sample holders placed in environmental chambers. In such applications the ell connects the sample holder to the slotted line with very little loss in accuracy.

¹ J. F. Gilmore, "Measurements of Dielectric Materials with the Precision Slotted Line," *General Radio Experimenter*, May 1966.

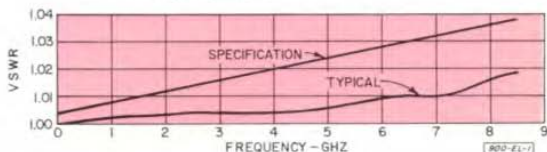

Figure 2. VSWR characteristics of precision ell.



SPECIFICATIONS

Frequency Range: Dc to 8.5 GHz.
Characteristic Impedance: $50 \Omega \pm 0.4\%$ at frequencies where skin effect is negligible.
VSWR: Less than $1.004 + 0.004 f_{GHz}$. See curve.
Electrical Length: $[10.00 + 0.0014 (f_{GHz})^2 \pm 0.02]$ cm.
Insertion Loss: Less than $0.017 \sqrt{f_{GHz}}$ dB.
Maximum Voltage: 1500 V peak.

Maximum Power: 10 kW up to 1 MHz;
 $10 \text{ kW} / \sqrt{f_{MHz}}$ above 1 MHz.
Mating Dimensions: 2.066 in. (5.246 cm) from center line of one connector to reference plane of second connector.
Over-all Dimensions: 2 11/16 by 2 11/16 by 3/8 in. (68 by 68 by 22 mm).
Net Weight: 10 oz (280 g).

Catalog Number	Description	Price in USA
0900-9527	Type 900-EL Precision 90° Ell	\$180.00

ADAPTORS TO 7-MM CONNECTORS

Two new adaptors permit interconnection of GR900 and 7-mm coaxial connectors.

The TYPE 900-QAP7 mates GR900 with the Amphenol APC-7 connector, and the TYPE 900-QPF7 mates GR900 with the Rohde & Schwarz Precifix A and Dezifix A Connectors.

SPECIFICATIONS

Frequency Range: Dc to 8.5 GHz.
Characteristic Impedance: 50.0 Ω nominal.
VSWR: Less than $1.003 + 0.002 f_{GHz}$.
Maximum Voltage: 1000 V peak.
Maximum Power: 6 kW up to 1 MHz;
 $6 \text{ kW} / \sqrt{f_{MHz}}$ above 1 MHz.
Dimensions: Length 2 1/8 in. (54 mm); max dia 1 1/16 in. (27 mm).
Net Weight: 3 1/2 oz (100 g).

Catalog Number	Description	Price in USA
0900-9791	Type 900-QAP7 Adaptor (GR900 to APC-7)	\$110.00
0900-9793	Type 900-QPF7 Adaptor (GR900 to Dezifix/ Precifix A)	110.00

PRECISION INNER-CONDUCTOR RODS

Precision rod and tube have been available from GR for some time for the custom fabrication of precision air lines, sliding loads, sample holders, short and open circuits, etc. The 27-inch precision rod formerly supplied is now replaced by 13-inch lengths, available in pairs by catalog number 0900-9507. The shorter lengths allow

us to maintain more rigid control of critical dimensions.

A limited supply of the old 27-inch rods (No. 0900-9508) is still on hand, and these longer rods will be shipped on order until the supply is exhausted.

Precision outer-conductor tube (No. 0900-9509) will continue to be sold in 27-inch lengths.

SPECIFICATIONS

Materials: Centerless-ground, stress-relieved, silver-layered brass rod (two supplied).
Outer Diameter: 0.24425 inch.
Accuracy of Diameter: ± 65 microinches.

Uniformity of Diameter: ± 25 microinches.
Surface Finish: 20 microinches, max.
Straightness: 0.003 TIR, max.
Length: 13 inches (330 mm). **Weight:** 7 oz (200 g).

Catalog Number	Description	Price in USA
0900-9507	Precision Coaxial Rod	\$22.00 per pair

NEW GR874 COMPONENTS

NEW ADAPTORS



Adaptors are available from GR874 to OSM-type miniature connectors and to Amphenol APC-7 precision 7-mm connectors.

Four GR874-to-OSM adaptors cover the mating requirements to both male and female OSM's in locking and non-locking versions. These adaptors mate with the following connector types: ASM, BRM, ESCAM, MICRO, MOB-

50, NPM, OSM, SRM, STM, and GRM. The vswr characteristics (Figure 3) apply only when the mating connector has the mating dimensions shown in Figure 4.

The new TYPE 874-QAP7L Adaptor mates a locking or nonlocking GR874 connector with an Amphenol APC-7 7-mm connector. The typical vswr of a single adaptor is shown in Figure 5.

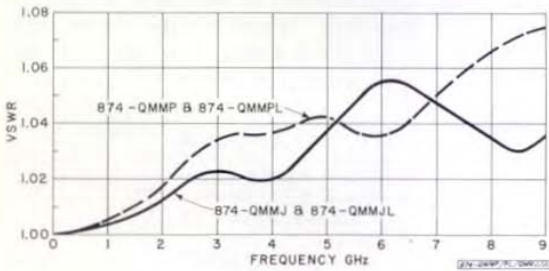

Figure 3. VSWR characteristics of Types 874-QMMJ and -QMMP Adaptors. (Values are typical for single adaptors.)

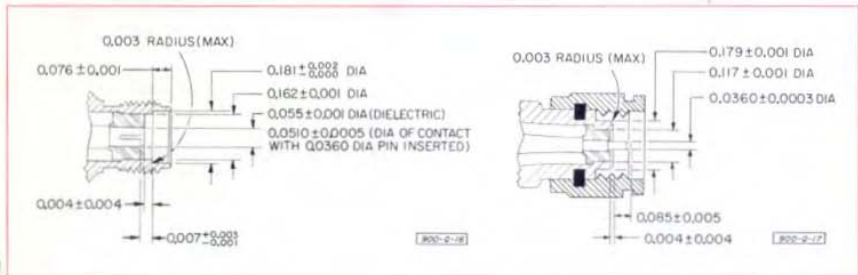

Figure 4. Critical mating dimensions for Types 874-QMMP and -QMMJ Adaptors.

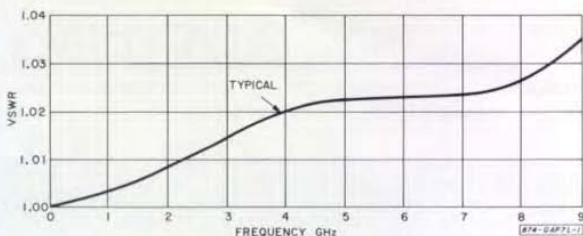

Figure 5. Typical VSWR characteristics of Type 874-QAP7L Adaptor.

SPECIFICATIONS

Frequency Range: Dc to 9 GHz.

VSWR: See curves.

Impedance: 50 ohms.

Maximum Voltage: 1000 V peak.

Catalog Number	Description	Includes	Mates With	Price in USA
0874-9722	Type 874-QMMJ Adaptor	OSM jack	OSM plug	\$16.00
0874-9723	Type 874-QMMJL Adaptor, Locking	OSM jack	OSM plug	17.25
0874-9822	Type 874-QMMP Adaptor	OSM plug	OSM jack	22.00
0874-9823	Type 874-QMMP L Adaptor, Locking	OSM plug	OSM jack	23.25
0874-9791	Type 874-QAP7L Adaptor	Amphenol APC-7		60.00

BIAS INSERTION UNIT



Figure 6. Type 874-FBL Bias Insertion Unit.

The TYPE 874-FBL Bias Insertion Unit (Figure 6) is used to bias coaxial devices and is a valuable component in slotted-line immittance measurements

on semiconductors. It consists of a coaxial tee with dc blocking in one arm and filtering in the other (see Figure 7). The filtering is especially helpful in transistor measurements where low-frequency isolation is required to prevent oscillation.

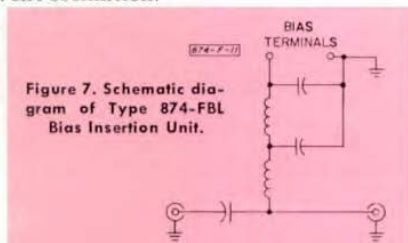

Figure 7. Schematic diagram of Type 874-FBL Bias Insertion Unit.

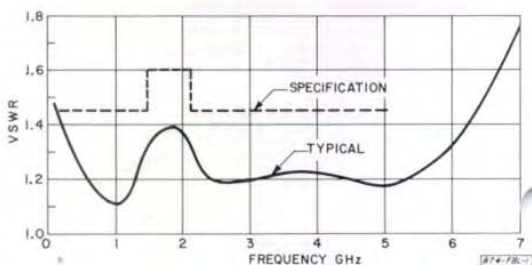

Figure 8. VSWR characteristics of Type 874-FBL Bias Insertion Unit.

SPECIFICATIONS

Current Rating: 2.5 A.

Voltage Rating: 400 V.

VSWR: See curve.

Insertion Loss: Typically less than 1.7 dB from

300 MHz to 3 GHz (except 2 dB at approx 1.8 GHz), less than 0.8 dB from 3 to 5 GHz.

Dimensions: 4 $\frac{3}{8}$ by 3 $\frac{3}{8}$ in (115 by 99 mm).Net Weight: 6 $\frac{1}{2}$ oz (185 g).

Catalog Number	Description	Price in USA
0874-9759	Type 874-FBL Bias Insertion Unit	\$75.00

NEW KEYED PANEL CONNECTOR



Figure 9. Type 874-PBRL58A Keyed Panel Connector.

A new recessed, locking GR874 panel connector has been designed for those who require positive, fixed orientation of the connector with respect to the panel. In the new 874-PBRLA family

of connectors, a key on the screw-mounted panel flange engages a keyway on the side of the connector, so that when the assembly is completed the connector cannot rotate, even if the clamping nut loosens.

Five models of this new connector are available to cover a wide range of cable sizes. General specifications are the same as those for other GR874 panel connectors listed in our catalog.

Catalog Number	Type	Fits	Price in USA
0874-9481	874-PBRLA	874-A2 cable	\$6.60
0874-9483	874-PBRL8A	(50-ohm) RG-8A/U, -9B/U, -10A/U, -87A/U, -116/U, -156/U, -165/U, -166/U, -213/U, -214/U, -215/U, -225/U, -227/U; (non 50-ohm) RG-11A/U, -12A/U, -13A/U, -63B/U, -79B/U, -89/U, -144/U, -146/U, -149/U, -216/U cables	6.60
0874-9485	874-PBRL58A	(50-ohm) 874-A3, RG-29/U, -55/U (series), -58/U (series), -141A/U, -142A/U, -159/U, -223/U cables	6.60
0874-9487	874-PBRL62A	(non 50-ohm) RG-59/U, -62/U (series), -71B/U, -140/U, -210/U cables	6.60
0874-9489	874-PBRL174A	(50-ohm) RG-174/U, -188/U, -316/U; (non 50-ohm) RG-161/U, -179/U, -187/U, -298/U cables	7.45

ROD AND TUBING

Rod and tubing are now available for fabricating custom GR874 components and air lines. The tubing is a 15 $\frac{7}{8}$ -inch section of Alballoy-plated brass, with an outer diameter of 0.624 (+0.000, -0.002) inch and an inner diameter of 0.5625 (± 0.0010) inch. The rod, also 15 $\frac{7}{8}$ inches long, is of high-conductivity

silver-plated brass, with a diameter of 0.24425 (± 0.00025) inch. Characteristic impedance of a coaxial line made up of this rod and tubing is 50 ohms $\pm 0.375\%$. Ends are already machined to accept 874-B or -BBL connectors, and machining instructions are included for shorter sections.

Catalog Number	Description	Price in USA
0874-9508	Inner-Conductor Rod	\$4.00
0874-9509	Outer-Conductor Tubing	4.00

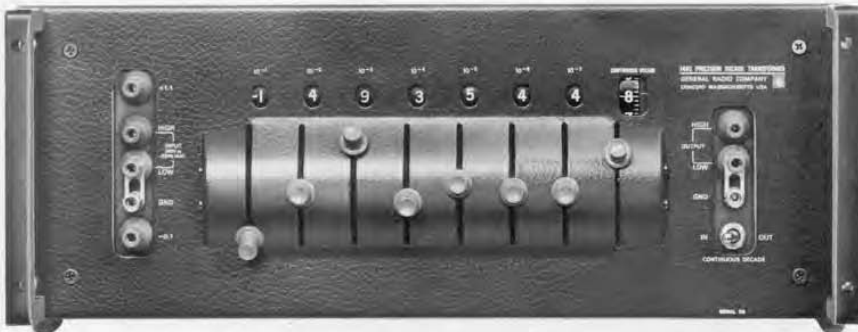

Figure 1. Type 1493 Precision Decade Transformer.

THE TYPE 1493 PRECISION DECADA TRANSFORMER

The new TYPE 1493 Precision Decade Transformer (Figure 1) is much more than just another "ratio box." Its accuracy (± 2 digits in the 10^{-7} decade), range (-0.1111111 to $+1.11111110$), resolution better than 1 part in 10^9 (with auxiliary equipment of appropriate sensitivity) and convenient, lever-switched, in-line readout set it apart from conventional ratio transformers.

Ratio transformers have been around for a long time. Most of our readers are probably familiar with their fundamental use in the measurement of an unknown turns ratio or of the magnitude ratio between two similar impedances (Figure 2). The addition of the resistor and capacitor shown in Figure 3 permits a closer measurement, by narrowing the null through phase balance. More complex circuits permit ratio measurements with a repeatability of a few parts in 10^9 .

Acceptable for calibration by the National Bureau of Standards, the 1493 can be used as a primary standard to

calibrate other ratio transformers. In educational and experimental laboratories it can be used as two of the adjacent ratio arms in many different

Figure 2. Diagram illustrating use of the 1493 in measurement of the ratio between the magnitudes of two impedances.

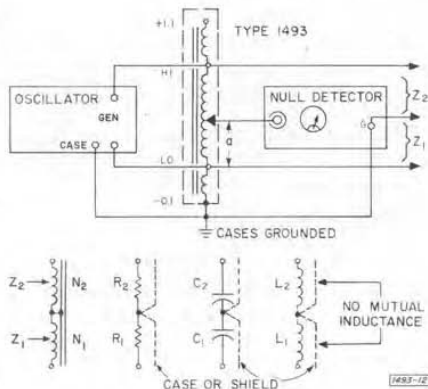

$$a = \text{ratio} = \frac{N_1}{N_1 + N_2} = \frac{R_1}{R_1 + R_2} = \frac{C_2}{C_1 + C_2} = \frac{L_1}{L_1 + L_2} = \frac{Z_1}{Z_1 + Z_2}$$

$$\frac{a}{1-a} = \frac{N_1}{N_2} = \frac{R_1}{R_2} = \frac{C_2}{C_1} = \frac{L_1}{L_2} = \frac{Z_1}{Z_2}$$

(Reversal of C subscripts caused by $X_C = \frac{1}{j\omega C}$.)

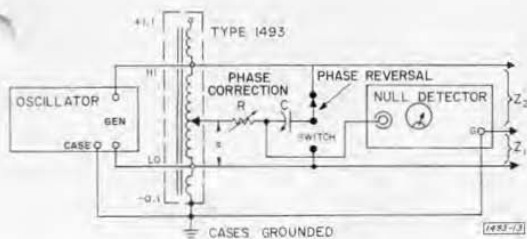

Figure 3. Setup similar to that of Figure 2, but with resistor and capacitor added for phase balance.

transformer bridge circuits for accurate impedance measurements.

Since the 1493 accuracy is basically determined by fixed turns ratios and by the relatively invariant properties of magnetic cores, no appreciable degradation of accuracy with time should occur. Calibration should literally last a lifetime, barring accidents.

The departures from tradition can be sensed from a look at the front panel (Figure 1).

The decade switches are the fingertip-lever type introduced by General Radio on the TYPE 1615-A Capacitance Bridge. Though they have been modified to meet the requirements of the

1493, they retain the convenient short-throw traverse from -1 to \times (or 10), as well as the easy-to-read, horizontal, in-line, digital display.

Seven of the levers control step switches; the eighth controls a continuous slide-wire decade that can be switched in to yield essentially infinite resolution.

The Transformers

The 1493 is an assembly of four separate transformers interconnected to produce seven switched decades (see Figure 4). Each transformer winding uses a multifilar cable whose individual conductors are all taken from the same

Figure 4. Schematic diagram showing interconnection of the four transformers.

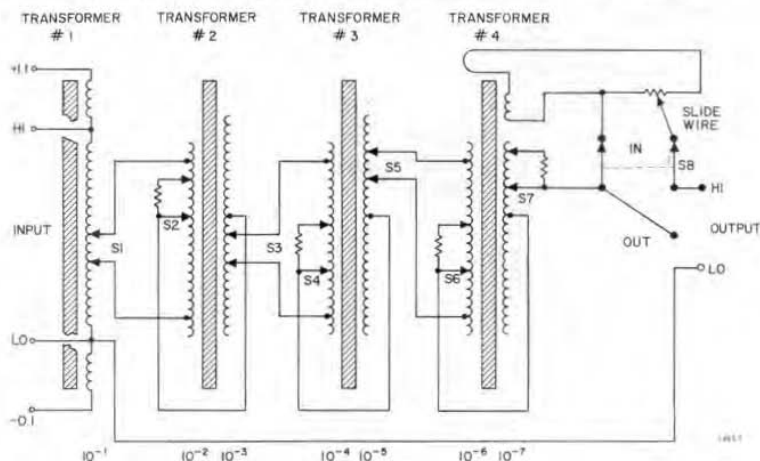



Gilbert Smiley came to General Radio in 1943 from General Control Company, where as Chief Engineer he was active in industrial automation development. An engineer in GR's Industrial Instruments Group, he has specialized in the design of transformers and other iron-core devices and is largely responsible for the Dura-trak brush-track coating used on Variac® auto-transformers.

wire spool to ensure equality of resistance. The cable is randomly disposed and lightly twisted and then is wound on an unusually large high-permeability core, with uniform spacing over 360 degrees. Individual conductors are connected end-to-end, aiding, and taps are brought out from certain junctions and ends. After testing, the four transformers are hot-sealed in a magnetically shielded catacomb. The sealant immobilizes the transformers and their connections and keeps out moisture. A second complete performance test follows sealing.

Switching Scheme

The switching of the 1493 Precision Decade Transformer differs from that of other units in several important respects. The first transformer has but one, 12-section winding. Its 10 center sections are connected to the input terminals, and the two end sections provide -0.1 and $+1.1$ over- and under-voltage connections. With only one winding on the first core, we are able to use the largest wire size capable of meeting the requirements for core excitation. Large wire means low resistance and reduced regulation error from loading.

Ten sections of the primary winding of the second transformer are bridged across successive decade sections of the first transformer by the action of the 10^{-1} decade switch (Figure 5).

Note that the connections to these 10 sections do not coincide with the primary taps but are placed midway between adjacent taps. This displaces the normal voltage per tap by one-half the section voltage. To compensate for this displacement, the secondary winding connection is made to the midpoint rather than to one end. The double offset results in a correct ratio indication from the switch settings. This switching scheme, unique to the 1493, offers two major advantages: (1) Maximum internal impedance (resistance

Figure 5. Diagram showing bridging connections of adjacent transformers.

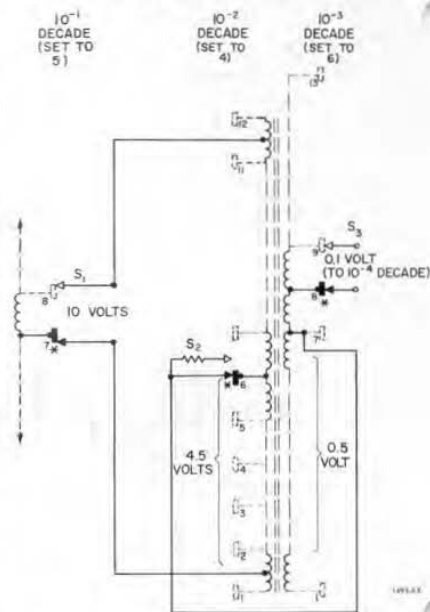

*Position of ← switch determines setting of significant digit.

and leakage inductance) is substantially reduced, and (2) internal impedance is kept more nearly constant versus ratio, a matter of considerable importance in many measurements.

As one proceeds from input to output, accuracy restraints are relaxed by an order of magnitude per decade. Consequently, transformers 3 and 4 have fewer turns on smaller cores. The reduction in turns lowers the contribution of these two transformers to internal impedance.

One conductor of the multifilar secondary winding on transformer 4 is isolated from the winding proper to

form a tertiary winding, which is traversed along the secondary by the 10^{-7} switch. This winding, supplemented by one additional turn around the core, aiding, drives the slide wire. The aiding turn, plus an adjustable resistance in series with the slide wire, allows the slide-wire voltage to be made equal to one step on the 10^{-7} switch. The tertiary winding and aiding turn connect to the slide-wire zero through a knife-edged contact to minimize zero ambiguity. A two-position switch permits operation of the 1493 with or without the slidewire, as desired.

— G. SMILEY

SPECIFICATIONS

RANGE: -0.1111111 to $+1.11111110$ with 7 step decades and continuous slide-wire decade in 10^{-8} position. Each step decade adjustable -1 to X (10). Continuous decade adjustable 0 to X .

ACCURACY

Linearity: Indicated ratio, measured at 100 V, 1000 Hz, with a resolution of $\pm 1 \times 10^{-3}$, agrees with a standard calibrated by the National Bureau of Standards to within their limits of uncertainty, stated as ± 2 digits in the 10^{-7} decade. At frequencies from 50 Hz to 2 kHz, ratio accuracy is approx ± 1 digit in the 10^{-6} decade. Incremental accuracy of last 4 step decades will be better than ± 2 parts in 10^5 . Continuous decade accurate to $\pm 1\%$.

Phase Error (at 1 kHz): $< \pm 6$ microradians for ratio settings from 0.1 to 1.0; $< \pm 40$ μ rad for 0.01 to 0.1; $< \pm 125$ μ rad for 0.001 to 0.01.

INPUT

Max Voltage: 350 V; below 1 kHz, $0.35f_{Hz}$ V.
Impedance: > 150 k Ω at 1 kHz; > 20 k Ω from 100 Hz to 10 kHz.

Direct Current: No dc should be applied to input.

OUTPUT

Impedance (dependent on ratio setting): Max: 3.5 Ω , 62 μ H; min: 0.5 Ω , 6 μ H. With slide-wire decade switched out, max resistance is reduced to 2.7 Ω .

Max Output Current: 1 A.

GENERAL

Terminals: Gold-plated GR 938 Binding Posts.
Accessories Available: Recommended generator and null detector for precise comparison or bridge applications: the 1311-A Audio Oscillator and 1232-A Tuned Amplifier and Null Detector or the combination 1240-A Bridge Oscillator-Detector.

Cabinet: Rack-bench. End frames for bench mount or rack-mounting hardware included.

Dimensions (width x height x depth): Rack, 19 x 7 x 8 $\frac{3}{8}$ in. (485 x 180 x 215 mm); bench, 19 x 7 $\frac{3}{8}$ x 10 $\frac{3}{4}$ in. (485 x 190 x 275 mm).

Net Weight: Rack, 28 lb (12.7 kg); bench, 30 lb (13.6 kg).

Shipping Weight: Rack, 41 lb (18.7 kg); bench, 43 lb (19.6 kg).

Catalog Number	Description	Price in USA
1493-9801	Type 1493 Precision Decade Transformer, Bench Model	\$1100.00
1493-9811	Type 1493 Precision Decade Transformer, Rack Model	1100.00

As we went to press we learned, with deep regret, of the sudden death of Mr. Gilbert Smiley, the author of the above article.

NEW VOLTAGE DIVIDERS OFFER RESOLUTION TO 10 PPM

Our popular resistive voltage dividers have passed through another stage of evolution. The "new breed" is the 1455 series, of which there are five versions. Beyond an obvious improvement in cosmetics (Figure 1), the new dividers boast tighter specifications and two five-dial units that extend resolution down to 10 parts per million.

Because these dividers are being used increasingly as adjustable elements in measurement and control systems, we have slimmed the package down to $3\frac{1}{2}$ inches and offer both bench and relay-rack models. Also, connections can be made at the rear as well as at the front, and the readout is in-line.

The five versions are the TYPES 1455-A, -AH, and -AL, and the TYPES 1455-B and -BH. The three -A dividers are four-dial units with a ratio range of 0.0001 to 1.0; the two -B's have five dials and a ratio range of 0.00001 to 1.0. An H in the suffix indicates a high impedance rating and consequently greater voltage-handling ability (up to 700 volts); the 1455-AL is a low-impedance divider useful at radio frequencies.

Uses

The decade voltage divider is an established means of obtaining accurately known voltage ratios. Among its many uses are the calibration of voltmeters, linearity measurements on continuously adjustable autotransformers and potentiometers, measurement of gain and attenuation, precise measurement of frequency-response characteristics of audio-frequency networks, and the determination of transformer turns ratios.

The new 1-k Ω 1455-AL will be found useful in testing voltmeters at low radio frequencies. It has a 3-dB response to 7.5 MHz and an output error of less than 1% at 1 MHz. Its low output impedance will make it attractive in many other areas where its low input impedance and voltage rating are not restrictive.

Some Comments on Accuracy Specifications

When these Kelvin-Varley dividers first appeared, we specified accuracy as a percent of reading. Later, the



Figure 1. Type 1455-BH Decade Voltage Divider.

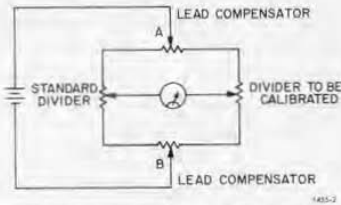

Figure 2. The comparison of two dividers with lead compensators.

use of the term "linearity" became popular for both resistive and ratio-transformer-type voltage dividers. Linearity here is essentially a percent-of-full-scale accuracy specification and equals the percent-of-reading accuracy times the indicated value. Because the indicated value is always less than 1, the linearity specification is a lower number than the percent-of-reading specification and therefore appears at first glance to represent greater accuracy.

We recognized the trend and included an over-all linearity specification, but we kept the percent-of-reading specification because it was the more stringent at low settings. Unfortunately, this created some confusion, for, although we meant both specifications to apply at all settings, some people felt that the percent-of-reading specification was overriding and that there were settings where the linearity specification did not hold. In order to clear up this point, we have gone over to the linearity specification completely and have extended it to all dial settings. This results in somewhat amazing numbers

for the linearity of settings for which the first few dials are set to zero.

(Actually, the old accuracy-of-reading specification was more stringent at many settings but didn't sound as good. For those who prefer an accuracy-of-reading specification and understand that it in no way negates the linearity specification, our old statement of $\pm 0.04\%$ of reading still applies.)

This linearity specification is somewhat complicated by the fact that the accuracy at very low settings depends somewhat on the method of connection, because of the residual resistance in the internal wiring and switches. Absolute linearity is determined with respect to the voltage output at zero setting; thus by definition there is no error at the zero setting. This type of linearity applies when the zero value of the measured device can be set equal to that of the divider. Consider, as an example, the comparison of two dividers using lead compensators (Figure 2), which are adjusted to bring the zero and unity points of both to coincidence.

When the divider is used as a simple three-terminal device, as shown in Figure 3, the voltage drop in the divider switches and wiring causes a small residual error (see Specifications). Although this error is quite low because of the silver-overlay multiple-contact switches used, at very low settings it can become a limitation on performance. When the input and output circuits do not have a common ground

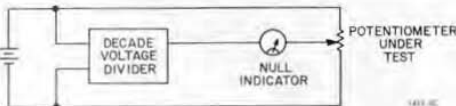

Figure 3. Divider connected to measure potentiometer linearity.

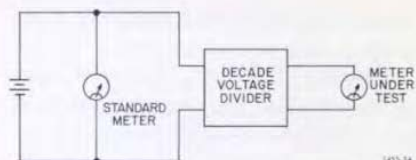

Figure 4. Divider connected to test low-level voltmeter.

and the output is taken between the output terminals, this voltage drop can be largely compensated for and a tighter specification is possible. An

example of such a four-terminal measurement is the circuit for checking a low-level voltmeter shown in Figure 4.

Extensive experience with the resistors used enables us to place a ± 20 -ppm, two-year linearity specification on the five-digit models and ± 30 ppm on the higher-impedance four-digit ones. The -AL model is specified at ± 50 ppm.

— H. P. HALL

A brief biographical sketch of Mr. Hall appeared in the June 1966 *Experimenter*.

SPECIFICATIONS

Type:	1455-AH	-A	-AL	-BH	-B
Dials:	4	4	4	5	5
Input Resistance:	100 k Ω	10 k Ω	1 k Ω	100 k Ω	10 k Ω
Input Voltage Rating: May be 20 ppm linearity change at full rating (see below)	700 V	230 V	70 V	700 V	230 V
Frequency Response (f_o at 3 dB down): (unloaded, at max output resistance setting)	85 kHz	850 kHz	7.5 MHz	69 kHz	690 kHz
Resolution (in ppm of input):	100	100	100	10	10
Linearity					
Absolute Linearity (in ppm of input): Output taken with respect to output zero setting at low audio frequencies with input voltage $< \frac{1}{2}$ rating.					
Ratio					
0.00001 to 0.00010	—	—	—	± 0.02	± 0.03
0.00010 to 0.00100	± 0.2	± 0.3	± 0.7	± 0.2	± 0.3
0.00100 to 0.01000	± 2	± 2	± 3	± 2	± 2
0.01000 to 0.10000	± 15	± 15	± 20	± 10	± 10
0.10000 to 1.00000	± 30	± 30	± 50	± 20	± 20
Terminal Linearity (in ppm of input) (add to absolute linearity):					
Four-terminal (output with respect to low output terminal):	± 0.004	± 0.04	± 0.4	± 0.004	± 0.04
Three-terminal (low terminals common or output with respect to low input terminal):	± 0.02	± 0.2	± 2	± 0.02	± 0.2
Max Output Resistance: (input shorted)	27.9 k Ω	2.79 k Ω	333 Ω	28.8 k Ω	2.88 k Ω
Effective Output Capacitance: (typical, unloaded)	67 pF	67 pF	67 pF	80 pF	80 pF

Frequency Characteristic:

Acts like simple RC circuit below f_o so that

$$\frac{E_o}{E_{in}} \approx \frac{\text{reading}}{\sqrt{1 + \left(\frac{f}{f_o}\right)^2}}$$

Tabulated value of f_o is at setting that gives max output resistance so that f_o at all other settings is higher. At $0.044f_o$, response is down < 0.1%.

Accuracy of Input Resistance: +0.015%, except for 1455-AL, which is +0.025%.

Temperature Coefficient: < 20 ppm for each resistor. Since voltage ratios are determined by

resistors of similar construction, net ambient temperature effects are very small.

Dimensions (width × height × depth): Rack models, $19 \times 3\frac{1}{2} \times 4\frac{5}{8}$ in. ($485 \times 89 \times 120$ mm); 4-dial bench models, $14\frac{3}{4} \times 3\frac{1}{2} \times 6$ in. ($375 \times 89 \times 155$ mm); 5-dial bench models, $17\frac{3}{16} \times 3\frac{1}{2} \times 6$ in. ($455 \times 89 \times 155$ mm).

Net Weight: Bench models, 4-dial, $6\frac{3}{4}$ lb (3.1 kg); 5-dial, $7\frac{3}{4}$ lb (3.6 kg).

Shipping Weight (est.): Bench models, 4-dial, $7\frac{1}{2}$ lb (3.5 kg); 5-dial, $8\frac{1}{2}$ lb (3.9 kg).

Add approx 1 lb (0.5 kg) to net and shipping weights for rack models.

Catalog Number	Description	Price in USA
Type 1455 Decade Voltage Dividers		
Bench Models		
1455-9700	1455-A, 4-dial, 10-k Ω	\$215.00
1455-9702	1455-AH, 4-dial, 100-k Ω	215.00
1455-9704	1455-AL, 4-dial, 1-k Ω	215.00
1455-9706	1455-B, 5-dial, 10-k Ω	255.00
1455-9708	1455-BH, 5-dial, 100-k Ω	255.00
Rack Models		
1455-9701	1455-A, 4-dial 10-k Ω	222.00
1455-9703	1455-AH, 4-dial, 100-k Ω	222.00
1455-9705	1455-AL, 4-dial, 1-k Ω	222.00
1455-9707	1455-B, 5-dial, 10-k Ω	260.00
1455-9709	1455-BH, 5-dial, 100-k Ω	260.00

PULSES FROM THE TONE-BURST GENERATOR

We are indebted to Mr. R. S. Caddy, Senior Lecturer at the University of New South Wales, for pointing out the useful properties of the General Radio Tone-Burst Generator, TYPE 1396-A, as a pulse generator. If the instrument is connected as for its usual application of producing tone bursts (interrupted or gated sine waves) and if the sinusoidal signal is removed from the gate input and replaced with a dc signal, the output becomes a pulse. The output is limited to about 7 volts positive or negative behind 600 ohms. The prf is controlled by the ac signal applied

to the TIMING INPUT terminals. If this timing-signal frequency is swept, the timing circuits of the 1396 will maintain a constant duty ratio by keeping the output-pulse duration a fixed number of periods of the timing signal.

If one alternately produces pulses and tone-bursts by switching the gate input from a dc to a sinusoidal signal source, the output signals from the tone-burst generator will have approximately the same shape frequency spectrum, but it will be centered at dc in the former case and at the sinusoidal frequency in the latter.

the  Experimenter

GENERAL RADIO COMPANY
WEST CONCORD, MASSACHUSETTS 01781

NEW PUBLICATIONS FROM GENERAL RADIO



A new series of applications notes, *Experiments for the Student Laboratory*, has been initiated by GR, and five of these educational aids are already in print. They are "The Motion of a Projectile," "Q of a Resonant Circuit," "Fourier Synthesis," "Distribution of Random Noise Voltages," and "Electronic Voltmeters." Any or all are free on request.

For those concerned with sound and vibration measurement, current and choice reading from GR now includes a new quarterly (*Noise Measurement*), a new series of application notes (*Noise Notes*), and a major revision of the renowned *Handbook of Noise Measurement*. Price of the *Handbook* remains \$1.00; the other publications are available for the asking.

GENERAL RADIO COMPANY
WEST CONCORD, MASSACHUSETTS 01781

PRINTED
IN
U.S.A.



IET LABS, INC in the **GenRad** tradition

534 Main Street, Westbury, NY 11590

TEL: (516) 334-5959 • (800) 899-8438 • FAX: (516) 334-5988

www.ietlabs.com